

**Disclaimer:**

Before operating equipment, please read all instructions in this manual. Failure to use this device properly may cause serious damage to the product or vehicle. PNP Inc. is not responsible for any damages or injuries that result from misuse.

**Caution:** Be sure the battery is fully charged or start the engine before use. **Using this product with low or partially charged battery may reduce battery reserves and cause difficulty in starting the vehicle.**

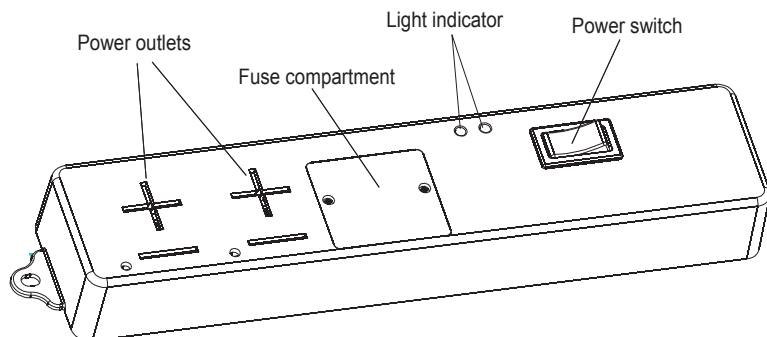

**Specification:**

Model	:	PowerHunt Power Strip PNP-100
Voltage & Rating	:	12Volt DC, 50A/600Watts
Dimension	:	357 x 74 x 53mm
Weight	:	0.82kg

**Functions:**

1. The PowerHunt Power Strip supplies 12V/DC, 50 amps to all PowerHunt appliances. The Power Strip comes with overload alert and red light for visual confirmation of power.
2. The PowerHunt Power Strip is designed for use with PNP System products only. Its patented design prevents improper connections and provides high output power.
3. **DO NOT modify or connect PowerHunt appliances to other power sources!**
4. **PNP products are specifically designed to accept the high amperage necessary for efficient performance. Normal 12 volt products CAN NOT BE USED WITH THIS SYSTEM.** The high amperage that is provided by the Power Strip will cause catastrophic failure in non-PNP products and may result in fire or damage to your vehicle. **Do not modify or connect other 12 volt appliances to the PowerHunt Power Strip.**

**Installation:** (Make sure the cable is connected to proper terminals)

1. Unscrew the base cover of the Power Strip.
2. Connect the Positive cable (**Red** color) to the (+) terminal; connect the Negative cable (**Red/Black** color) to the (-) terminal. Reinstall the base cover onto the Power Strip.
3. Connect the other end of Positive cable to the (+) terminal of the battery; connect the other end of Negative cable to the (-) terminal of the battery.
4. Tighten all screws. Loose screws will generate heat and may cause fire or damage to the battery terminal.



**Changing Fuse:**

1. Remove Phillips head screw.
2. Move fuse holder left then up.
3. Carefully remove old fuse and insert new one. Be sure to align black marks on fuse and fuse holder.
4. Replace compartment door and tighten screws.

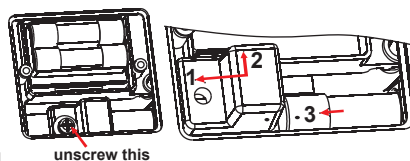

**Important:** Be sure to align black marks on Fuse and Fuse holder when installing. Failure to align marks may result in fuse breakage.

**Operation Procedure:**

**Before Use**

1. Turn OFF the Power Strip.
2. Turn OFF all the PowerHunt appliances.

**Applying Power**

1. Plug in the PowerHunt appliances to Power Strip outlet.
2. Turn ON the Power Strip. The Green LED light will be on.
3. Turn ON the PowerHunt appliances.
4. Audible alarm will sound if too many appliances are being used and the power draw is exceeding designed use level. Continued use while exceeding manufactures recommendations may result in damage to the unit. Such damage is not covered under manufacturer warranty.

**After Use**

1. Turn OFF all the PowerHunt appliances.
2. Turn OFF the Power Strip.
3. Unplug the appliance.

**Caution:**

1. DO NOT operate the Power Strip when the vehicle or boat is in motion.
2. DO NOT immerse the Power Strip in water or any other liquids.
3. DO NOT move the Power Strip when in use.
4. DO NOT cover the Power Strip when in use.
5. Keep the Power Strip away from curtains or any flammable materials when in use.
6. Unplug appliances and turn OFF the Power Strip after use.
7. The power outlet is designed for use with PowerHunt appliances ONLY.

**Maintenance:**

1. Unplug the Power Strip before cleaning. Use damp cloth to clean the Power Strip. DO NOT apply corrosive detergent.
2. Return the Power Strip to supplier if the Power Strip does not operate or the case has been broken.

**One Year Limited Warranty:**

PowerHunt products are guaranteed to be free from defects in materials and workmanship under normal use for a period of ONE year from the date of purchase.

This warranty does not cover damage or malfunction caused by product deterioration or by accident, misuse, abuse or commercial use. Scratches, stains or damage from improper cleaning or maintenance are not covered by this warranty. Incidental or consequential damages are expressly excluded by this warranty.

To claim under this warranty, you are required to present the original sales receipt/invoice as proof of purchase. Please keep your receipt safely.

**IMPORTANT:**

Please complete warranty registration through website [www.power-hunt.com](http://www.power-hunt.com), failure to register this warranty within 30 days from the date of purchase will invalidate the warranty.

**Warranty Return Policy:**

If the PowerHunt product becomes defective during the warranty period, please contact our Customer Service Department and request a return authorization (R/A) number.

Once we receive your request, our Customer Service Team will process the authorization and call, fax or email you the Return Authorization Number.

When you are ready to ship the product back to PNP Inc., the following is the procedure you need to follow:

- Clearly mark the R/A number on the shipping box. Shipments missing a legible and correct R/A number marked outside the package will be refused and PNP Inc. will not be responsible for them.
- Ship ONLY the product(s) for which the R/A number was issued. PNP Inc. will not be responsible in any way for unauthorized returned product.
- Include in the package a proof of purchase, such as a copy of the original invoice/sales receipt.
- Attach a written description of the problem of the product being returned.
- Make sure that the product is securely packed before shipping. Remember that you are responsible for the product until we receive it. PNP Inc. will not be responsible for and does not warrant against damage of any sort incurred prior to our receipt of the product.
- Product is to be shipped freight prepaid to PNP Inc. within seven (7) days of issuance of R/A number. PNP Inc. reserves the right to cancel without notice any R/A number for which the product has not been received within 21 days of issuance.
- Shipments received without a proper R/A number will be refused.

**Customer Service:**

PNP Inc.  
Address: P.O. Box 156, Fortville, IN 46040 Tel: (317) 485-4597 Fax: (317) 485-5386  
Toll free number: 888-485-4597 Website: [www.power-hunt.com](http://www.power-hunt.com) Email: [info@power-hunt.com](mailto:info@power-hunt.com)

**Register Product Warranty OnLine**  
[www.power-hunt.com](http://www.power-hunt.com)